

Fastener type HGW 40

Advantages:

- quick mounting
- high distance balance
- installable in all positions
- anti-noise system
- fire-resistant

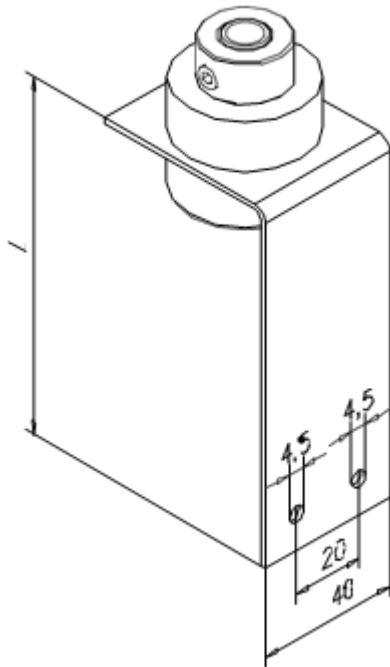

Technical Data

- Fastener for underconstruction, with rubber.
- For 8mm welding studs.
- Maximum recommended workload = 250 N / fastener
- Tensile breaking strength = min. 2300 N

Dimensions:

L = 20, 40, 60, 100
other dimensions on request

Material:

- Galvanized steel (standard)
- Stainless steel (1.4301, 1.4571)

Rubber:

- 40 shore \pm 5 standard,
- 15 and 50 shore on request

